

# HOLLOW CORE SLABS

OMAN اوفبوليت عمان  
**OPHIOLITE**  
*No Lead, Others Follow*





*We Lead. Others Follow.*

## HOLLOW CORE SLABS

A hollow core slab is a precast slab of prestressed concrete typically used in the construction of floors in multi-story buildings. The slab has been especially popular in countries where the emphasis of construction has been on precast concrete.

The precast concrete slab has tubular voids extending the full length of the slab, typically with a diameter equal to the 2/3-3/4 of the slab. This makes the slab much lighter than a massive floor slab of equal thickness or strength. Reduced weight is important because of transportation cost and less cost of material (concrete). The slabs are typically 1200 mm wide with standard thicknesses between 150 mm and 500 mm.



Oman Ophiolite is committed to providing the best-quality products and services in the industry. Our clients expect that our products will always equal, and often exceed, required standards in terms of materials and workmanship. Oman Ophiolite has a proud history of providing quality pre-cast products to Oman's construction market.

P.O. Box. 457, P.C 124, Sultanate of Oman  
Tel / Fax: +968 2444 6412  
Mob: +968 9988 0481  
E-mail: [info@ophioman.om](mailto:info@ophioman.om)



Scan for download  
the pdf version of this  
brochure





# CONTENTS

A. GENERAL	2	E. OPENINGS IN HOLLOW CORE SLABS	10
A.1 STANDARD SECTIONS	2	F. CONCENTRATED LOADING	12
A.2 MANUFACTURING	3	F.1 SUSPENSIONS	12
A.3 MATERIALS	3	G. M&E INSTALATIONS	15
A.4 PRODUCTION TOLERANCES	4	H. SOUND INSULATION	15
A.5 MANUFACTURING	4	I. FIRE RESISTANCE	15
A.6 NARROW SLABS	4	J. THERMAL RESISTANCE	15
A.7 DESIGN	5	K. PRE-FINISHED CEILING	16
B. DIAPHRAGM ACTION	6	L. QUALITY ASSURANCE	16
B.1 CONCRETE TOPPING	7	M. HANDLING AND TRANSPORT	17
B.2 BEARING LENGTH	7	N. ERECTION	17
C. ADAPTABILITY TO SUPPORTING STRUCTURES	8	N.1 JOINT INFILL AND CONCRETE SCREEDS	17
D. CANTILEVER SLABS	9	O. TECHNICAL DETAILS	18

# A. GENERAL

**Prestressed precast hollow core slabs are the most widely used type of precast flooring.**

The system offers numerous benefits to engineers and architects because it gives maximum strength with minimum weight, versatility in span / depth ratio, smooth soffit and speed of erection which leads to an economical way to construct floors.

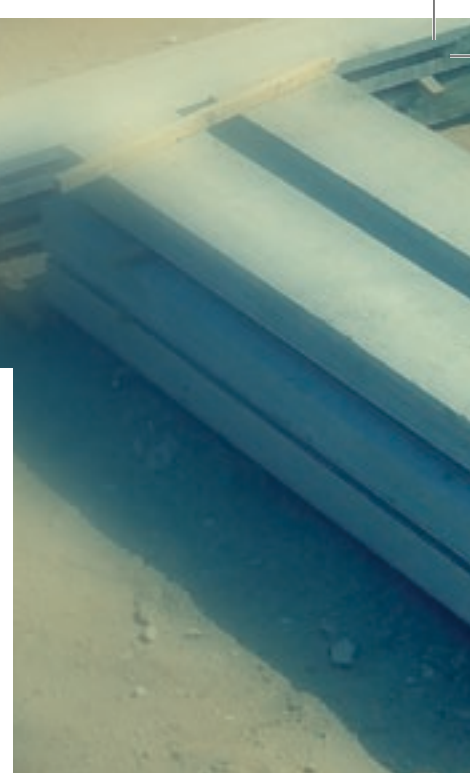

## A.1 STANDARD SECTIONS

The nominal width of hollow core slabs is 1200mm, inclusive of the longitudinal joint. The common standard cross sections are shown in Figure 1 and the technical details / load-bearing capacities are given on page 12 to 18. Special hollow core slabs for specific usage e.g. heavy loads, 4-hours fire resistance, etc are also available.

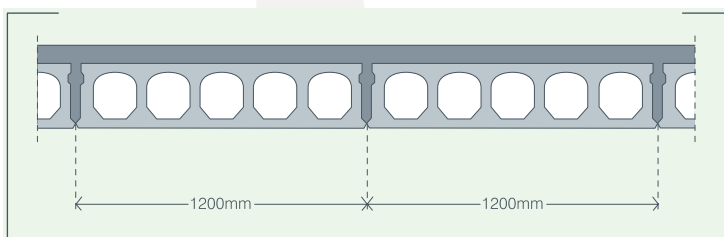

*Typical longitudinal joint pro file for arrangement of adjacent hollow core slabs.*

THICK (MM)	SECTION	TYPE	SLAB WEIGHT (KN/M <sup>2</sup> )	JOINTED WEIGHT (KN/M <sup>2</sup> )
150		150HCS	2.11	2.23
200		200HCS	2.48	2.61
265		265HCS	3.39	3.59
320		320HCS	3.93	4.17
400		400HCS	4.94	5.24

*Figure 1: Standard precast hollow core slabs (Standard width is 1,200mm)*



## A.2 MANUFACTURING

Hollow core slabs are manufactured on long-line prestressing beds using a state-of-the-art automated production process. Maturity of the concrete can be accelerated by heat curing which provides shorter cycle time to provide speedy delivery. Cured hollow core slabs are then cut to the desired length using diamond-tipped automatic saw once the concrete has attained sufficient strength.



*Long-line prestressing beds*

## A.3 MATERIALS

Hollow core slabs are made from zero-slump concrete with C60 compressive strength. The prestressing tendons are indented 7 - wire low relaxation strands to BS 5896-1980 or ASTM A416-94 GRADE 270 with a strength of 1860 N/mm<sup>2</sup>. Tendon size is normally of 9.3- 9.6mm and 12.5-12.9mm in diameter.



*Extruder machine for production of hollow core slabs*

## A.4 PRODUCTION TOLERANCES

1. Length (L):	$\pm 15 \text{ mm}$ or $L/1000$ <sup>1)</sup>
2. Thickness (h):	$\pm 5 \text{ mm}$ or $h/40$ <sup>1)</sup>
3. Width (b) : whole slab narrow slab:	+ 0 - 6 mm $\pm 15 \text{ mm}$
4. Orthogonality end face (p):	$\pm 10 \text{ mm}$
5. Camber before erection ( $\Delta^d$ ) <sup>2)</sup> :	$\pm 6 \text{ mm}$ or $L/1000$ <sup>1)</sup>
6. Warping (a):	$\pm 10 \text{ mm}$ or $L/1000$
7. Flatness (y):	10 mm under a lath of 500 mm
8. Holes and recesses (t) cut in fresh concrete: cut in hardened concrete:	$\pm 50 \text{ mm}$ $\pm 20 \text{ mm}$

<sup>1)</sup> Whichever is the larger

<sup>2)</sup> Deviated from the calculated precamber

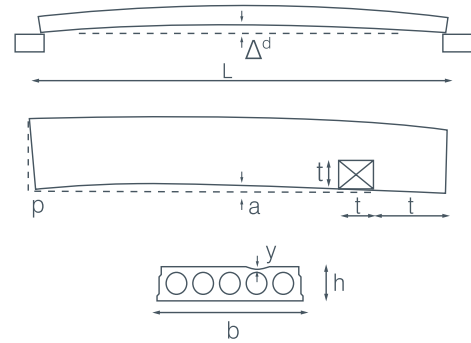

## A.5 MANUFACTURING

Hollow core slabs can be cut to an angle of 0° - 45°.

Two-way angles are also possible.

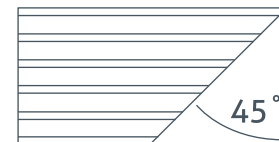

## A.6 NARROW SLABS

Standard hollow core slab width is 1,200mm and the columns/walls centers should preferably be of modular coordinated dimension of 12M (where 1 M = 100mm). Otherwise, floor slabs generally should be arranged in a way to minimize cast in situ strips and to maximize the usage of full 1,200mm wide slabs. However hollow core slabs can be cut to narrower widths should the need arises.

### Minimum widths of narrow slabs

SLAB THICKNESS (MM)	MIN. WIDTH (MM)
150	350
200	450
265	540
320	690
400	690

All slabs can be produced with reduced widths. The narrow slabs are produced by cutting the standard width slabs after the extrusion. The location of the longitudinal cut should correspond to the location of a longitudinal void, at a distance of 35mm-70mm from the prestressed strands, for 150mm - 265mm thickness and 50mm -100mm for 320mm-500mm thickness. It is recommended that the cut edge is placed over a wall or beam as the cut edge will be straight without chamfer as for full width slabs.

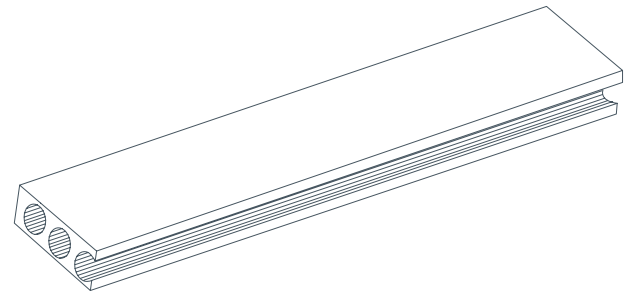

## A.7 DESIGN

The design is generally based on the following Standards and Technical Guide:

**British Standard BS 8110:1997** - Structural use of concrete

**BS-EN 13369** - Common rules for concrete products

**BS-EN 1168** - Hollow Core Slabs

**FIP Recommendations** - Precast Prestressed Hollow Core Floors  
**PCI-Handbook**

Hollow core slabs can be regarded as the best section for a structural flexural member. The design of the cross-section allows the concrete to be used optimally both in the compression and tension zones.

Theoretically, the concrete below the compression zone which is redundant is omitted by longitudinal voids, thus reducing the

weight of slab. By applying prestressing force with tendons at the bottom of slab, this will increase the tensile capacity of the slab.

This gives hollow core slabs the distinct advantage for higher load carrying capacity and achieving long span capability.

A floor consisting of jointed hollow core slabs provides a monolithic slab structure. In order to achieve this, the joint between adjacent hollow core slabs must be properly grouted. The jointed hollow core slabs are capable of distributing vertical loads within the slab 'field' and provide a rigid diaphragm to transmit lateral loads to the stabilizing structure.

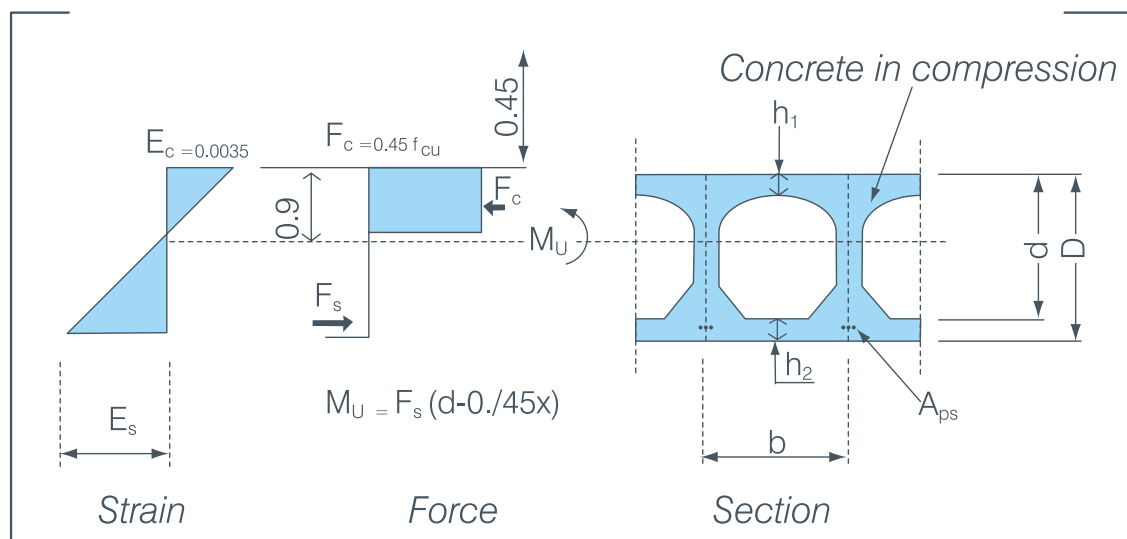

*Strain and force distribution in hollowcore slab*

## B. DIAPHRAGM ACTION

The diaphragm action of hollow core floors is realized through a good joint design.

The peripheral reinforcement plays a determinant role, not only to cope with the tensile forces of the diaphragm action but also to prevent the horizontal displacement of the hollow core units, so that the longitudinal joints can take up shear forces. The positioning and minimum proportioning of ties, required by Eurocode 2, is shown in the figure below.

Hollow core slab floor diaphragm action ▶

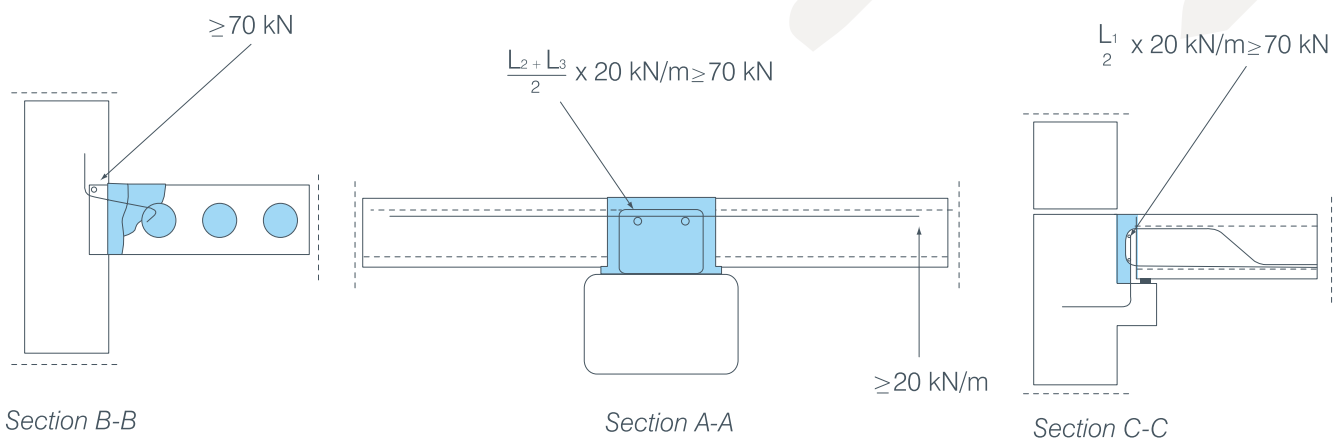
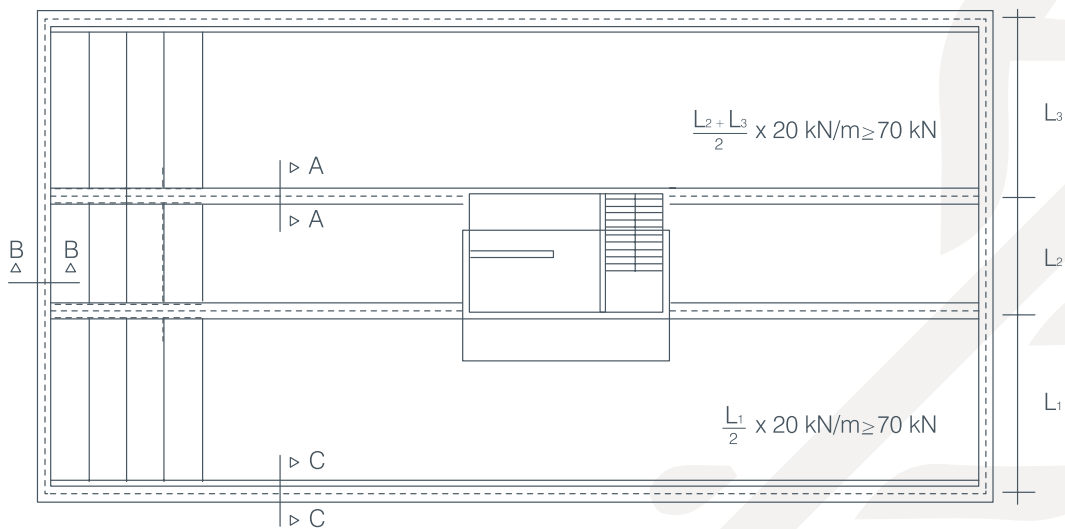
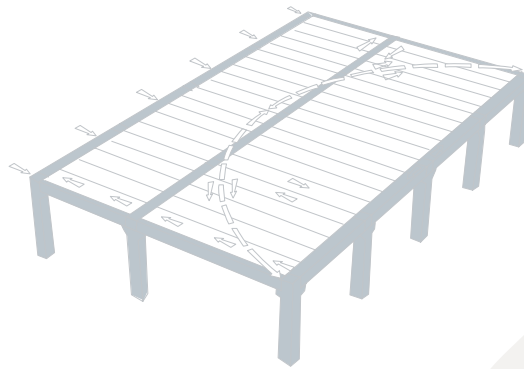



## B.1 CONCRETE TOPPING

Hollow core slabs can be used for floors without structural topping. However it is recommended that a layer of concrete topping is provided in order for easy leveling of the top of the slabs. In addition, hairline cracks can be minimized on floors and this topping can also serve as a barrier to prevent water leakage through the joints of hollow core slabs, as well as embedment of electrical conduits.

Generally, the thicknesses of topping shall be specified to be between 50mm to 85mm with C30 - C40 concrete.

In case of Seismic action, frequent changes of loads, important point load or requirement for increased load bearing capacity a structural topping can be provided.

The structural topping is normally designed to prevent crack at serviceability limit state and should normally be reinforced with a layer of wire mesh and negative reinforcement. Stability

tie reinforcement may also be provided wholly within the concrete topping.

Hollow core slabs with topping is designed as a composite structure, hence increasing the load-bearing capacity of the slab.

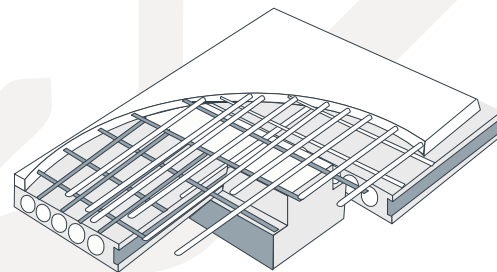

**Concrete topping with a layer of wire mesh and bars for hogging moment over beam support.**

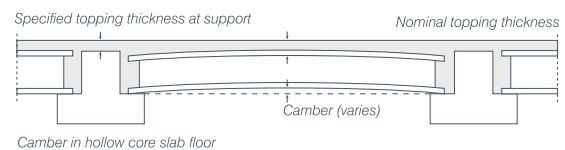

## B.2 BEARING LENGTH

The nominal bearing length of simply supported hollow core floor units is given in the table. Erection on plywood spacers and tamping with concrete mortar ensure a uniform bearing.

Supporting Material	Slab thickness	Support length a	
		Normal length	Minimum effective length
Concrete or steel	≤ 265 mm	80 mm	60 mm
	≥ 320 mm	100 mm	80 mm
Block work	≤ 265 mm	100 mm	80 mm
	≤ 320 mm	120 mm	100 mm

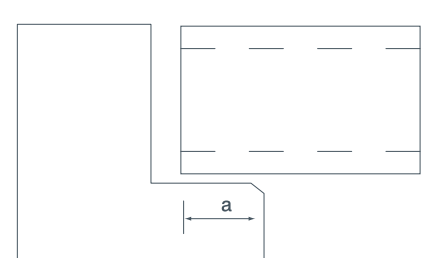

# C. ADAPTABILITY TO SUPPORTING STRUCTURES

Hollow core slabs can be supported on virtually all types of structural materials. Slabs can be supported by cast in situ or precast beams, steel beams or by precast load-bearing walls and masonry walls.

For erection on steel structures, precast beams and walls, the slabs can be placed directly on the support structure or on a bearing strip.

On in-situ concrete structures the Hollow core slabs are placed on plywood spacers for leveling purpose, and tamped with concrete mortar to ensure continuous support of the full width of the slab.

Support connections with the reinforcement shown

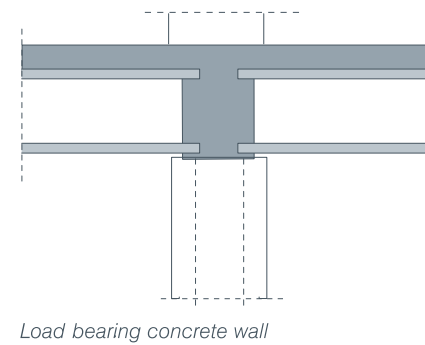
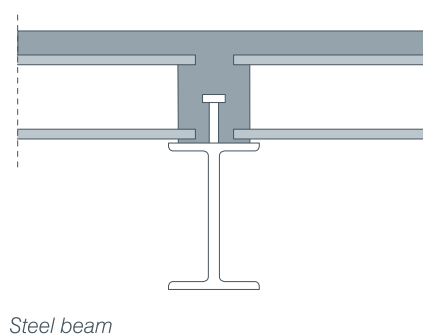
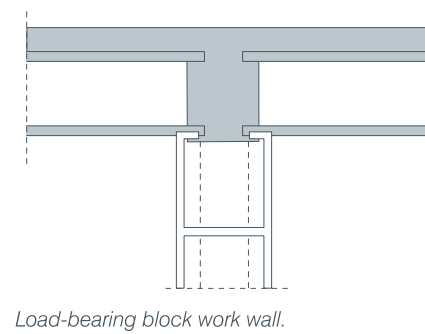
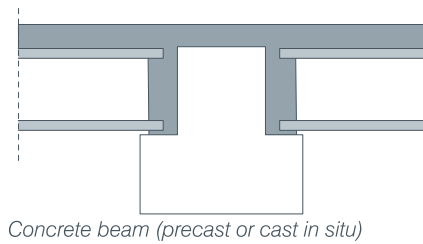
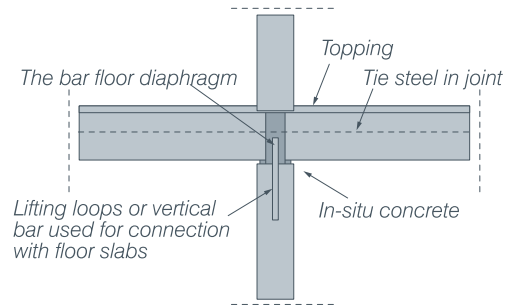
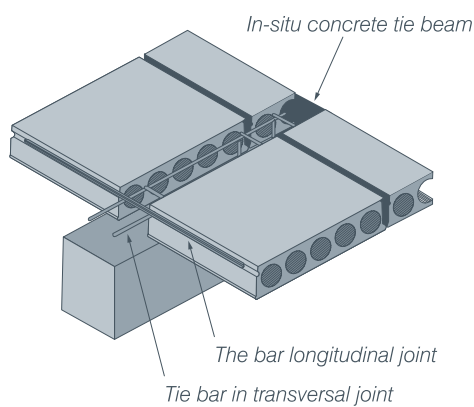



## D. CANTILEVER SLABS

Hollow core slabs can be cantilevered by 1m to 2m depending on the slab thickness by providing top strands. The cantilevered slabs can be used for making balconies, bay windows, extensions and other decorative structures.

Shorter extensions may be realized on site using additional reinforcement embedded in slab joints or in the concrete topping.

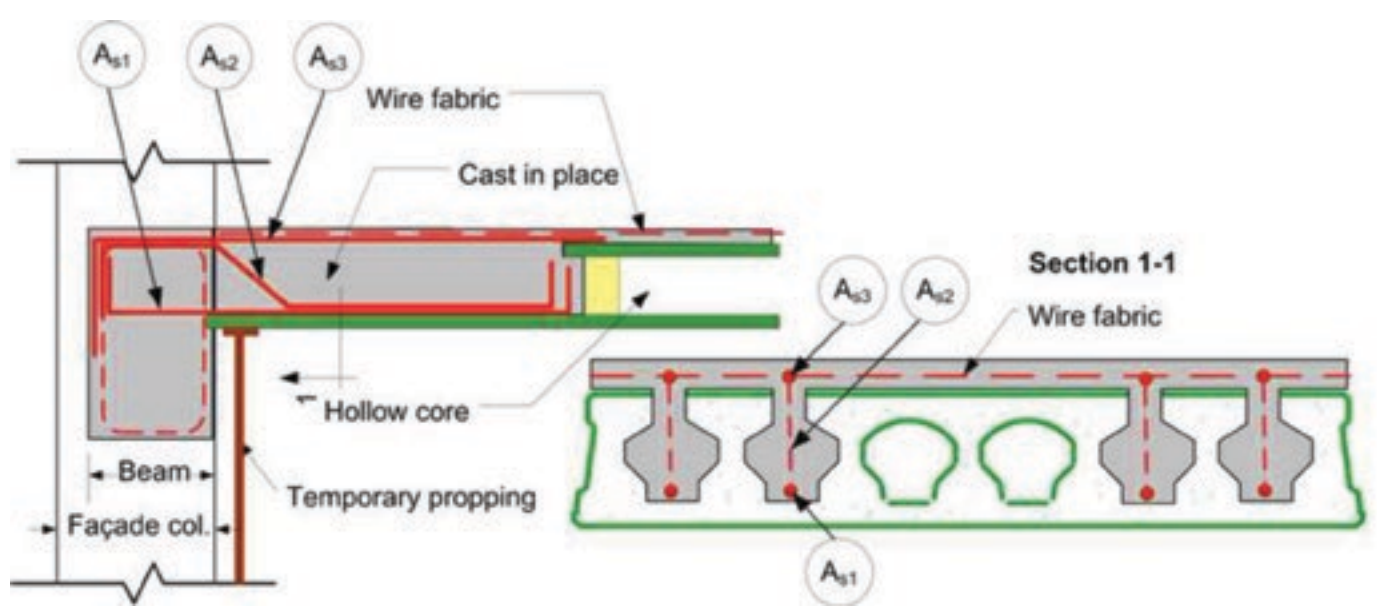

▲  
Special composite bearing arrangement for beam & HCS

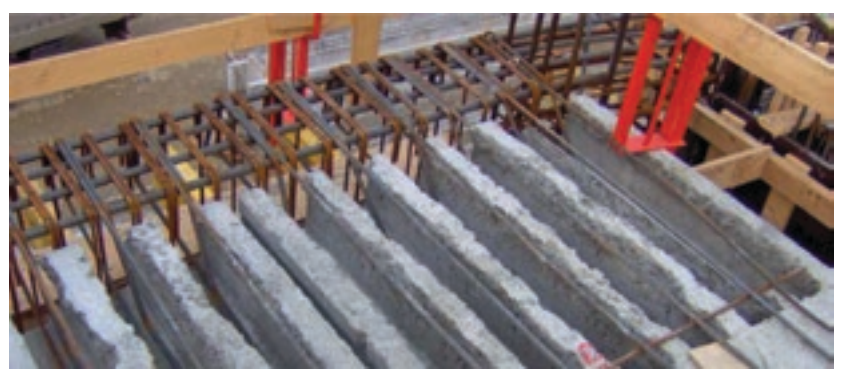

## E. OPENINGS IN HOLLOW CORE SLABS

**Different sizes of openings can be made into hollow core slabs:**

Very large opening where one or more slabs are totally cut: The load from the slab(s) with no support will be transferred to the adjacent slabs mainly through the shear keys and through a "hidden" steel or cast in situ concrete spreader beam. Medium size openings in hollow core slabs are usually made at the factory. The reduced cross section has to be designed to withstand the design loads.

Small openings and recesses can be made at site by diamond tipped coring.

Holes may be circular or rectangular, and up to three are normally permitted in the same cross-section. Holes are considered to be in the same cross-section if they are less than 750mm apart in the longitudinal slab direction.

When making holes, great care must be taken not to damage the slab. It is particularly important that the prestressing stands are not cut without the permission of Oman Ophiolite Precast's designer.

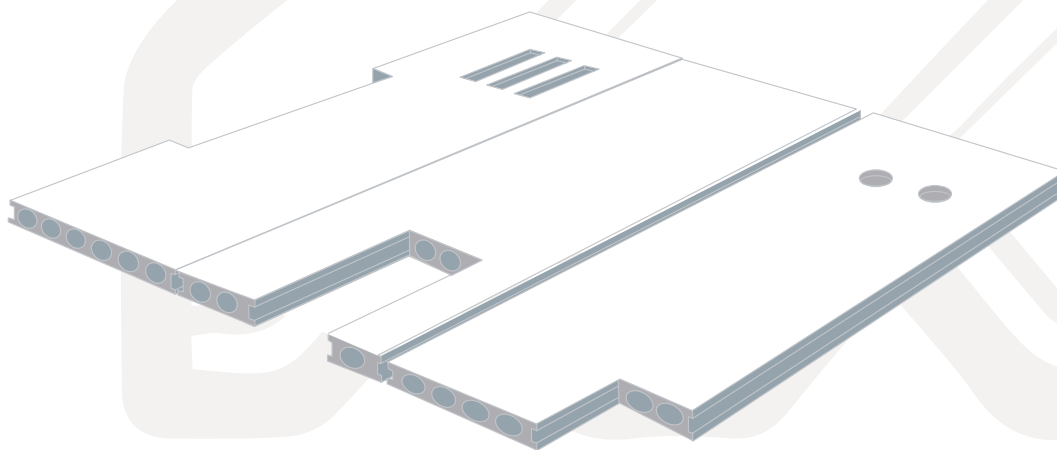

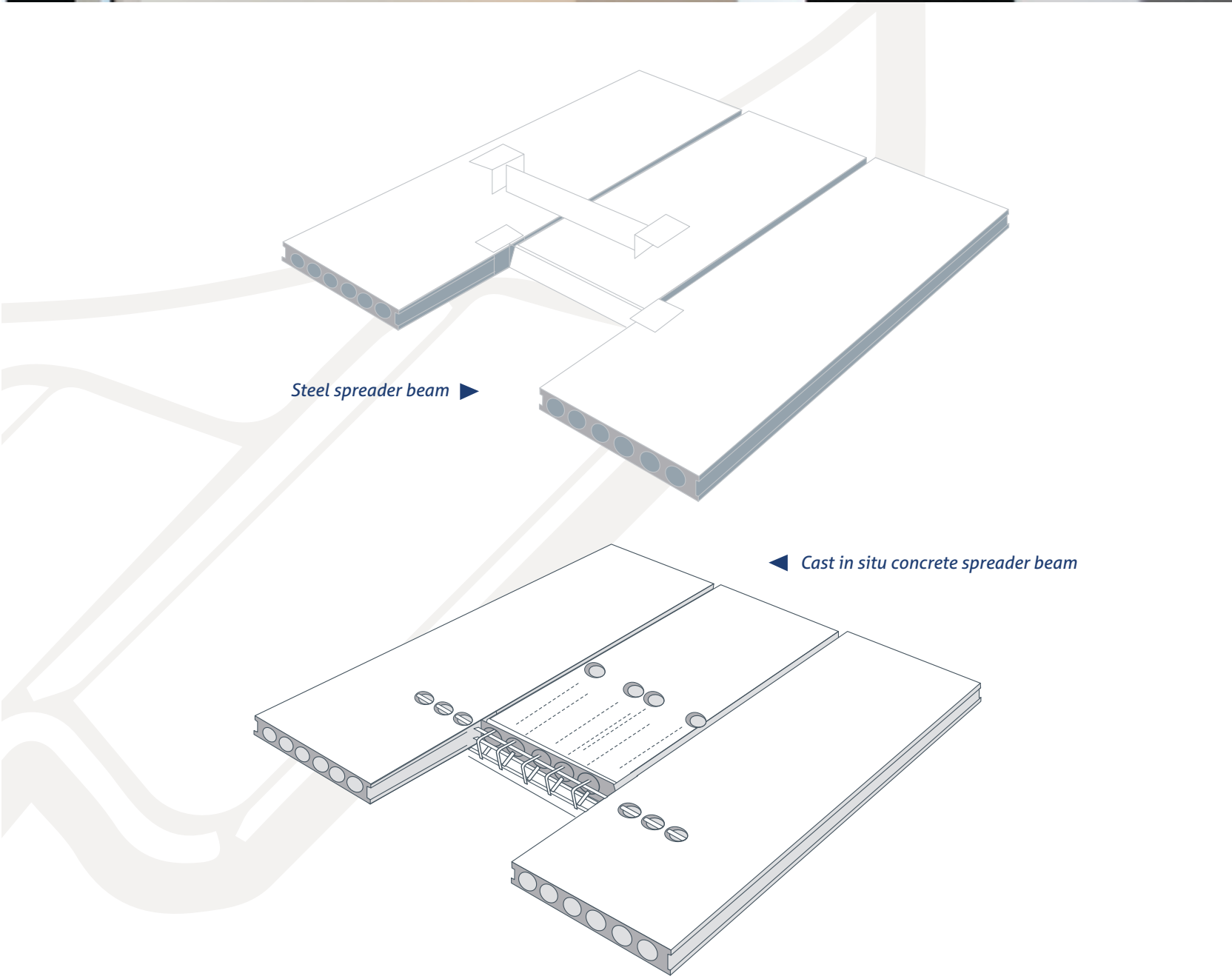
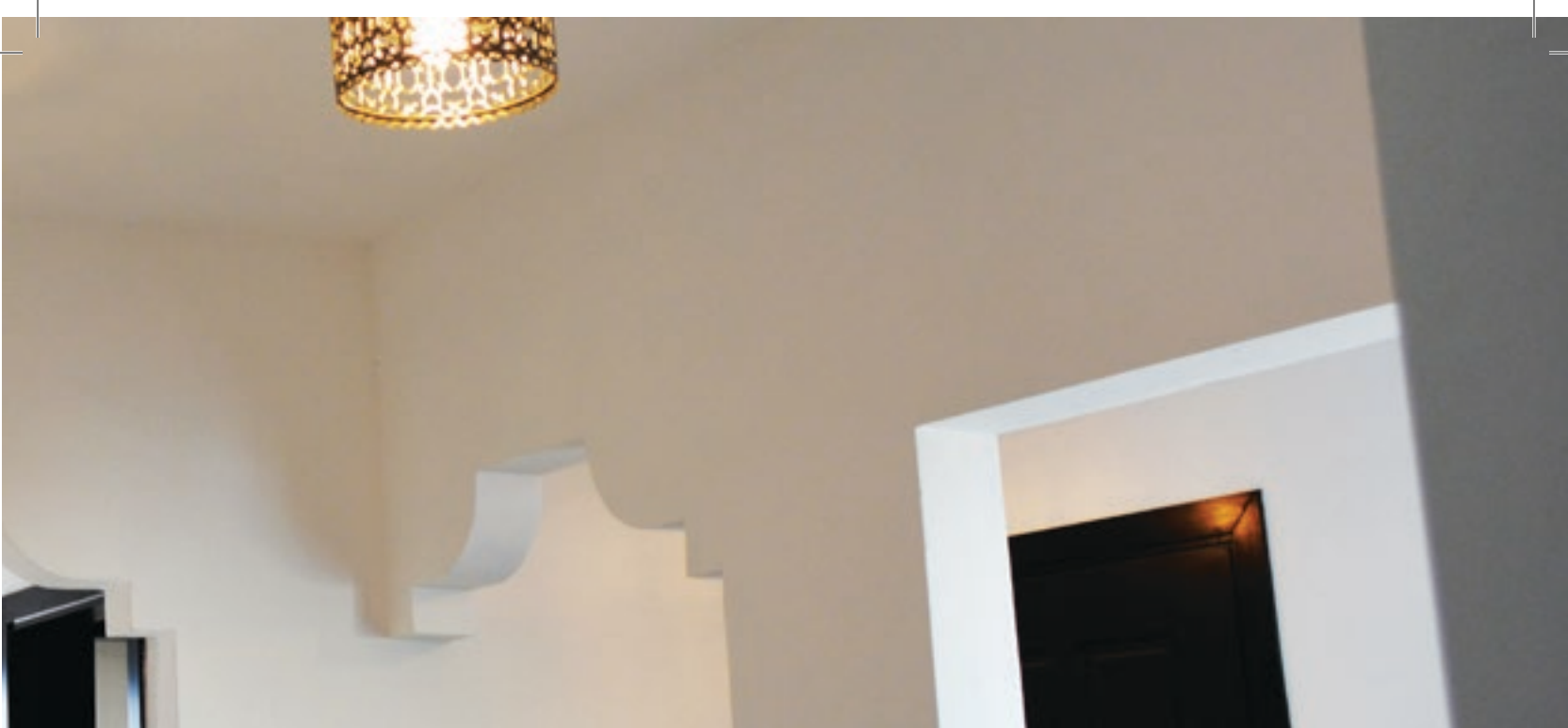

## F. CONCENTRATED LOADING

Floors composed of prestressed hollow core elements behave almost as monolithic floors for transverse distribution of line or point loads. The loads are transmitted through the profiled longitudinal joints. Extra care shall be taken to check the overall moment and shear capacity of the hollow core slabs.

As per BS 8110, part 1, clause 5.2.2.2 line loads can be distributed over the lesser of the width of three hollow core slabs plus the width of the loaded area or the quarter of the span on either side of the loaded area.

Distribution of point load from one slab to the next through grouted shear key

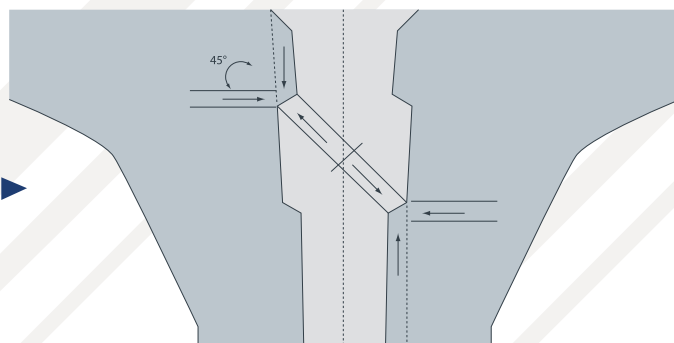

### f.1 SUSPENSIONS

#### Light Weight Suspensions

Lightweight suspensions can be fixed by drilling the fixing to the lower surface of the slab at a hollow core. Here are some examples of permissible suspension loads:

Anchor	Drill depth (mm)	Maximum Suspension (kN)
Spring bolt plug M4	Up to hollow core	0.3
Spring bolt M6	Up to hollow core	1.0
Expansion bolt M6	30	1.5
Expansion bolt M8	30	2.3
Expansion bolt M10	40	3.5

#### Light duty Fastening

Usage Electrical conduits and ceiling  
Light duty services e.g. signage, etc...

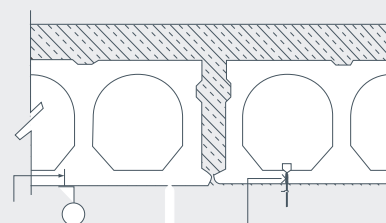

Rawplug  
Nylon Masonry  
Anchors or  
equivalent.

HILTI hollow deck  
anchor HTW TWIN  
or equivalent.

Light hangers using drill in anchor bolt

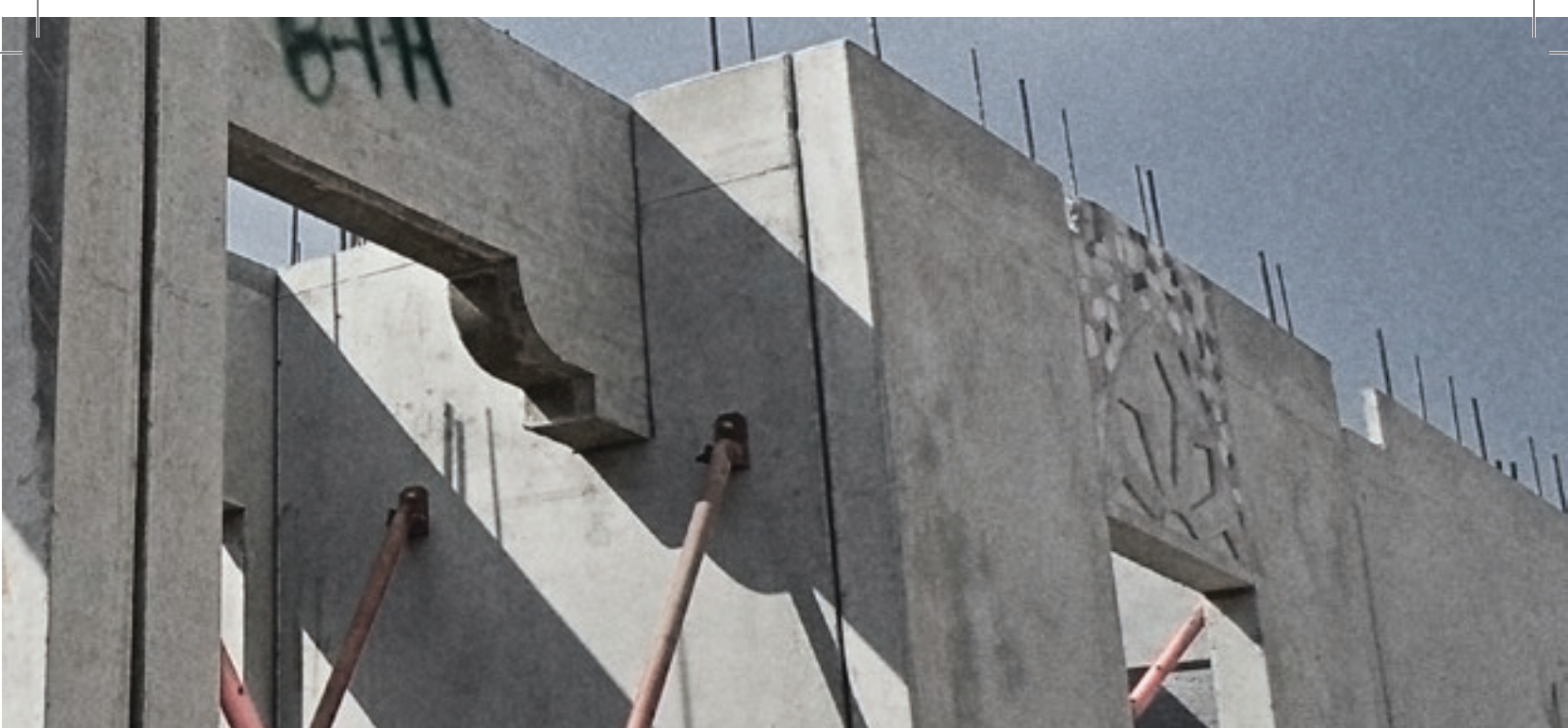

### Heavy Suspensionst

It is advisable to fix any heavy suspensions to slab interfaces or with a through slab suspension bolt. For Fe 370 MN/m<sup>2</sup> suspension bolts, permissible loads are as follows:

Bolt size (mm)	Maximum load (kN)
Ø 6	5.5
Ø 8	10
Ø 10	15
Ø 12	20

### Heavy duty Fastening

**Usage** Heavy / large equipments (subject to loading by respective nominated sub-contractor for approval).

Motors (e.g. for smoke-spilled, etc.)

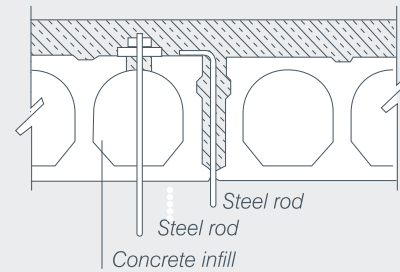

*Heavy duty hangers are fixed through the slab and supported from the top of the slab*





## G. M&E INSTALLATION

## H. SOUND INSULATION

**Concealed electrical conduit and telephone trunking can be laid on top of hollow core slabs before topping is cast which is illustrated in the photograph shown.**

Conduits are normally run in the screed and holes are drilled on site through the slab for installation of the electrical boxes. If a false ceiling is provided, it is most common that the conduit is placed between the soffit of the slabs and the false ceiling.

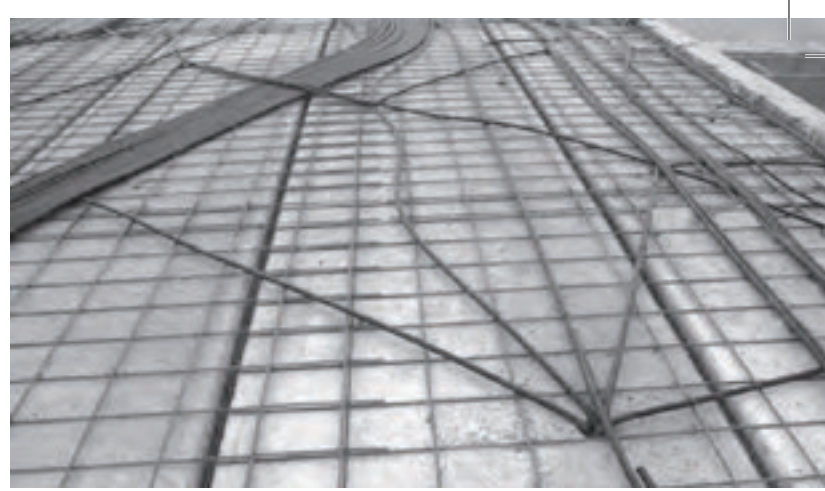

**Hollow core slabs used as structural floor units offer excellent sound insulation properties associated with concrete and the longitudinal voids give further dampening effect. This will contribute to less sound transmission between floors.**

The airborne sound reduction index  $R_w$  for hollow core slabs according to BS 8233, 1987 are as follows:

Type	$R_w$ (dB)
150 HCS	50
200 HCS	53
265 HCS	56
320 HCS	58
400 HCS	60
150 HCS + 60mm Topping	53
200 HCS + 60mm Topping	56
265 HCS + 60mm Topping	59
320 HCS + 60mm Topping	61
400 HCS + 60mm Topping	63

## I. FIRE RESISTANCE

Standard hollow core slabs are designed for 1.0 hours fire rating. Fire resistance shall be in accordance with the recommendations of BS 8110. Special slabs can be produced up to a fire rating of 4 hours, if required .

## J. THERMAL RESISTANCE

Thermal insulation values are normally only significant at roof levels, where an insulation layer has to be placed on top of the slab to achieve good thermal resistance.

The U-value ( $W/m^2k$ ) for hollow core slabs are as listed below:

Type	U-value ( $W/m^2k$ )
150 HCS	8.33
200 HCS	6.67
265 HCS	5.26
320 HCS	5.00
400 HCS	4.55

## K. PRE-FINISHED CEILING

The Soffit of Precast hollow core slabs offers an aesthetically pleasing prefinished ceiling. It is completely set at one plane level without the necessity to introduce secondary beams. Omission of the secondary beams will give the functional advantage of greater overall headroom and better appearance of the ceiling.

Soffits of hollow core slabs are smooth and ready to paint with no requirement for additional plaster. Joints in the soffit between Precast hollow core slabs can be closed, if required for aesthetical reasons. A method statement can be provided from Oman Ophiolite's design department.

## L. QUALITY ASSURANCE

Quality control will be performed according to Oman Ophiolite standard quality control procedures in our own laboratory.

Compressive Concrete strength is determined by standard test cubes from the wet concrete and these are tested in accordance with BS 1881:Part108:1983 and BS 1881:Part116:1983.

The concrete strength is at least 60% of the design strength before the tension in the prestressing strands is released. After the slabs have been crosscut, strand slippage must remain within permissible limits. After production, all slabs are checked visually for cracks, bro-

ken edges and strand slippage before they are released for erection.

Oman Ophiolite carries out full structural tests at fixed intervals to determine the actual shear and bearing capacity of the slabs.

## M. HANDLING AND TRANSPORT

**Handling, loading and storage arrangements on delivery should be such that the hollow core slabs are not subjected to forces and stresses which have not been catered for in the design. The units should have semi-soft (e.g. wood) bearers placed at the slab ends. Where they are stacked one above the other, the bearers should align over each other.**

When stacking units on the ground site, the guidelines will be similar to the above. The ground should be firm and the bearers horizontal, such that no differential settlement may take place and cause spurious forces and stresses in the components. During handling, provisions shall be taken to ensure safe manipulation, for example safety chains under the slab.

## N. ERECTION

**The erection of the hollow core floor slabs should be done according to the instructions of the design engineer. Oman Ophiolite will supply written statements of the principles of site erection, methods of making structural joints and materials specification on request.**

Hollow core slabs are designed for quick and easy installation. However, free access for the mobile crane and delivery truck to the place of erection at site must be provided. Completion of erection without interruption is crucial. Hollow core slabs are easy to install using lifting booms and clamps available from Oman Ophiolite.

### N.1 JOINT INFILL AND CONCRETE SCREEDS

The longitudinal joints between the floor units should be filled using concrete grade C25 to C35, containing a 10mm maximum size aggregate. The floor units should be moistened prior to placement of in-situ concrete. The joints should be filled carefully since they fulfill a structural function both in the transversal load distribution and the horizontal floor diaphragm action.

When a structural screed is to be used, it is advisable to fill the longitudinal joints immediately prior to the casting of the screed. The workability should be ensured by using

concrete with a slump between 50 and 100 mm. The wet concrete should be spread evenly over the floor area as quickly as possible. Mechanical vibrating beams are used to compact the concrete. The screed must be power floated or rough tamped in the usual manner depending on the type of floor finish. The topping screed should contain a shrinkage reinforcement mesh and extraordinary care should be taken to ensure the curing is ensured properly.

# O. TECHNICAL DETAILS

Oman Ophiolite Precast's hollow core slabs are produced and designed as previously described, and have the characteristics as shown below.

The load bearing capacity of our standard slabs are shown on the graph and on the following pages. Kindly note that special slabs can be designed for project specific requirement in addition to the standards shown in this brochure.

### General information about using the load tables:

Both limit states (quls and qsls ) shall be controlled.

Shear capacity is based on a nominal bearing length of 80mm, allowing 20mm tolerance on site.

qsls is never given bigger than quls/1.5

quls is never given bigger than qsls x1.6

Msls is never given bigger than Muls/1.4

### Basis for the design:

Basis for the design is BS 8110: Part1:1997, simply supported class 2 members.

All section- and rial properties which are used for the design are given on the data below.

For structural topping load tables the slab is calculated as a composite section, with a topping concrete strength of  $f_{cu} = 35 \text{ MPa}$ .

SPAN	150HCS	200HCS	265HCS	320HCS	400HCS
3	18.0				
4	11.0	18.0	29.8		
5	8.0	13.2	23.7		
6	5.4	10.2	17.6		
7	3.0	8.4	14.8		
8		6.6	12.0	16.4	21.2
9		4.0	9.8	14.7	18.7
10			7.6	13.0	16.2
11			5.2	9.2	14.3
12			3.4	6.4	12.4
13			2.0	4.4	9.5
14				2.8	6.6
15				1.6	4.9
16					3.2
17					2.0



### OMAN OPHIOLITE HCS LOAD CURVES

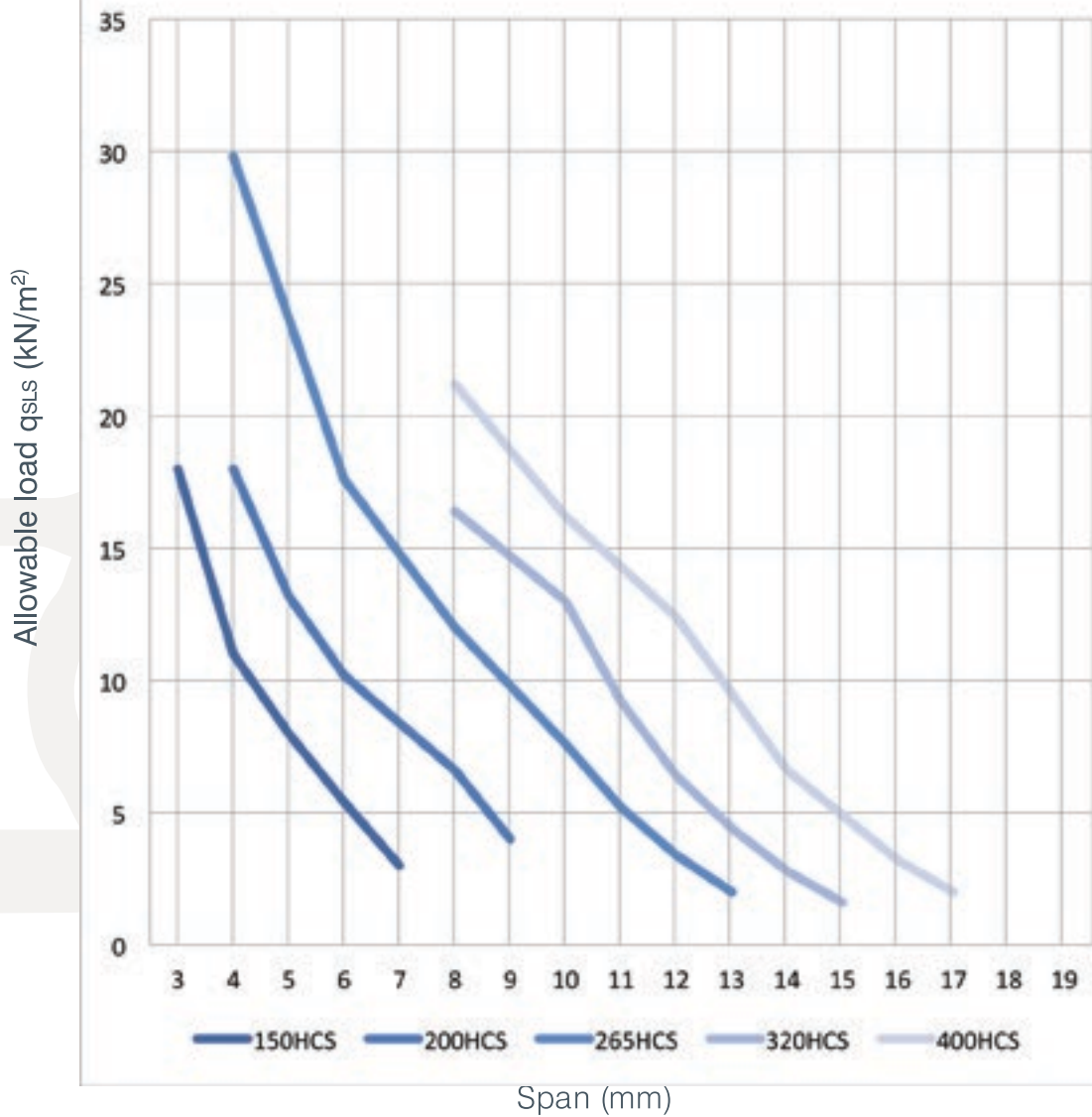

Design load  $q_{SLs}$  ( $kN/m^2$ ) in excess of slab self weight





## HOLLOW CORE SLAB TYPES



## HOLLOW CORE SLAB TYPE 150 HCS

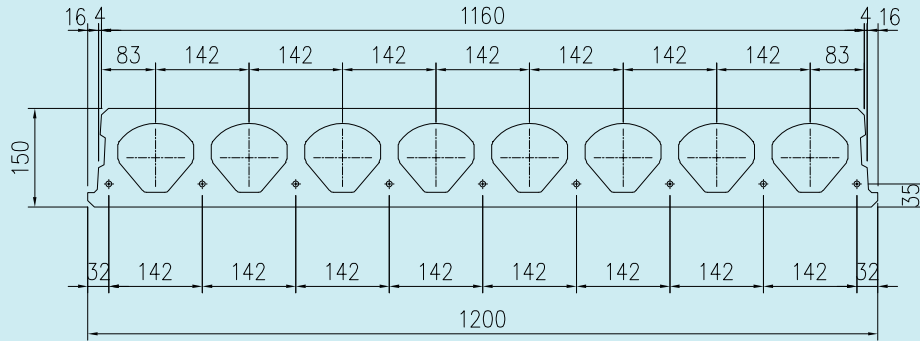

**Load Table 150 HCS**

STRAND PATTERN	BEARING CAPACITY PER SLAB UNIT (1.20 M WIDTH)	SPAN (m)	3	4	5	6	7	8	9
4S - 9.3mm $M_{cr} = 31.8 \text{ kN-m}$	$M_{SLS} = 26.5 \text{ kN-m}$	$q_{SLS} \text{ (kN/m}^2\text{)}$	14.8	7.2		1.8			
	$M_{ULS} = 32.8 \text{ kN-m}$	$q_{ULS} \text{ (kN/m}^2\text{)}$	22.2	10.8		2.7			
	$V_{UD} = 54.8 \text{ kN}$	c (mm)	-1.2	-1.7		2.3			
5S - 9.3mm $M_{cr} = 35.7 \text{ kN-m}$	$M_{SLS} = 31.3 \text{ kN-m}$	$q_{SLS} \text{ (kN/m}^2\text{)}$	18.0	9.4		2.8			
	$M_{ULS} = 40.8 \text{ kN-m}$	$q_{ULS} \text{ (kN/m}^2\text{)}$	27.0	14.1		4.2			
	$V_{UD} = 55.0 \text{ kN}$	c (mm)	-1.6	-2.4		-1.6			
6S - 9.3mm $M_{cr} = 39.5 \text{ kN-m}$	$M_{SLS} = 32.9 \text{ kN-m}$	$q_{SLS} \text{ (kN/m}^2\text{)}$	18.0	11.8		3.8			
	$M_{ULS} = 48.6 \text{ kN-m}$	$q_{ULS} \text{ (kN/m}^2\text{)}$	27.0	17.7		5.7			
	$V_{UD} = 55.2 \text{ kN}$	c (mm)	-2.1	-3.2		-3.3			
7S - 9.3mm $M_{cr} = 42.9 \text{ kN-m}$	$M_{SLS} = 35.7 \text{ kN-m}$	$q_{SLS} \text{ (kN/m}^2\text{)}$		12.0		4.4	2.2		
	$M_{ULS} = 56.3 \text{ kN-m}$	$q_{ULS} \text{ (kN/m}^2\text{)}$		18.0		6.6	3.3		
	$V_{UD} = 55.3 \text{ kN}$	c (mm)		-3.9		-5.1	-3.3		
8S - 9.3mm $M_{cr} = 47.7 \text{ kN-m}$	$M_{SLS} = 39.8 \text{ kN-m}$	$q_{SLS} \text{ (kN/m}^2\text{)}$		12.0		2.5	2.6		
	$M_{ULS} = 63.8 \text{ kN-m}$	$q_{ULS} \text{ (kN/m}^2\text{)}$		18.0		3.8	3.9		
	$V_{UD} = 55.5 \text{ kN}$	c (mm)		-4.7		-6.9	-5.7		
9S - 9.3mm $M_{cr} = 50.0 \text{ kN-m}$	$M_{SLS} = 42.4 \text{ kN-m}$	$q_{SLS} \text{ (kN/m}^2\text{)}$		11.6		5.4	3.0		
	$M_{ULS} = 71.3 \text{ kN-m}$	$q_{ULS} \text{ (kN/m}^2\text{)}$		17.4		8.1	4.5		
	$V_{UD} = 55.6 \text{ kN}$	c (mm)		-5.5		-8.6	-8.1		

**Load Table 150 HCS + 60mm Screed**

STRAND PATTERN	BEARING CAPACITY PER SLAB UNIT (1.20 M WIDTH)	SPAN (m)	3	4	5	6	7	8	9
4S - 9.3mm $M_{cr} = 54.4 \text{ kN-m}$	$M_{SLS} = 46.1 \text{ kN-m}$	$q_{SLS} \text{ (kN/m}^2\text{)}$	24.0	12.2	6.8	4.0	2.4		
	$M_{ULS} = 50.1 \text{ kN-m}$	$q_{ULS} \text{ (kN/m}^2\text{)}$	36.0	18.3	10.2	6.0	3.6		
	$V_{UD} = 72.6 \text{ kN}$	c (mm)	-1.2	-1.7	-1.7	-0.7	3.3		
5S - 9.3mm $M_{cr} = 56.9 \text{ kN-m}$	$M_{SLS} = 47.4 \text{ kN-m}$	$q_{SLS} \text{ (kN/m}^2\text{)}$	10.1	14.4	9.0	5.6	3.4		
	$M_{ULS} = 61.9 \text{ kN-m}$	$q_{ULS} \text{ (kN/m}^2\text{)}$	15.2	21.6	13.5	8.4	5.1		
	$V_{UD} = 62.5 \text{ kN}$	c (mm)	-1.7	-2.5	-3.0	-2.5	1.1		
6S - 9.3mm $M_{cr} = 74.3 \text{ kN-m}$	$M_{SLS} = 61.9 \text{ kN-m}$	$q_{SLS} \text{ (kN/m}^2\text{)}$	23.2	16.4	11.4	7.2	4.6		
	$M_{ULS} = 74.2 \text{ kN-m}$	$q_{ULS} \text{ (kN/m}^2\text{)}$	34.8	24.6	17.1	10.8	6.9		
	$V_{UD} = 70.5 \text{ kN}$	c (mm)	-2.0	-3.1	-4.0	-4.0	-2.5		
7S - 9.3mm $M_{cr} = 79.9 \text{ kN-m}$	$M_{SLS} = 66.6 \text{ kN-m}$	$q_{SLS} \text{ (kN/m}^2\text{)}$		15.6	12.0	8.6	5.8		
	$M_{ULS} = 86.0 \text{ kN-m}$	$q_{ULS} \text{ (kN/m}^2\text{)}$		23.4	18.0	12.9	8.7		
	$V_{UD} = 69.7 \text{ kN}$	c (mm)		-3.8	-5.1	-5.6	-4.6		
8S - 9.3mm $M_{cr} = 79.0 \text{ kN-m}$	$M_{SLS} = 65.8 \text{ kN-m}$	$q_{SLS} \text{ (kN/m}^2\text{)}$		14.8	11.0	8.8	6.8		
	$M_{ULS} = 97.6 \text{ kN-m}$	$q_{ULS} \text{ (kN/m}^2\text{)}$		22.2	16.5	13.2	10.2		
	$V_{UD} = 69.1 \text{ kN}$	c (mm)		-4.6	-6.3	-7.3	-6.9		
9S - 9.3mm $M_{cr} = 93.1 \text{ kN-m}$	$M_{SLS} = 77.6 \text{ kN-m}$	$q_{SLS} \text{ (kN/m}^2\text{)}$		14.2	10.6	8.4	6.8		
	$M_{ULS} = 109.0 \text{ kN-m}$	$q_{ULS} \text{ (kN/m}^2\text{)}$		21.3	15.9	12.6	10.2		
	$V_{UD} = 67.9 \text{ kN}$	c (mm)		-5.3	-7.4	-8.9	-9.2		

## HOLLOW CORE SLAB TYPE 200 HCS

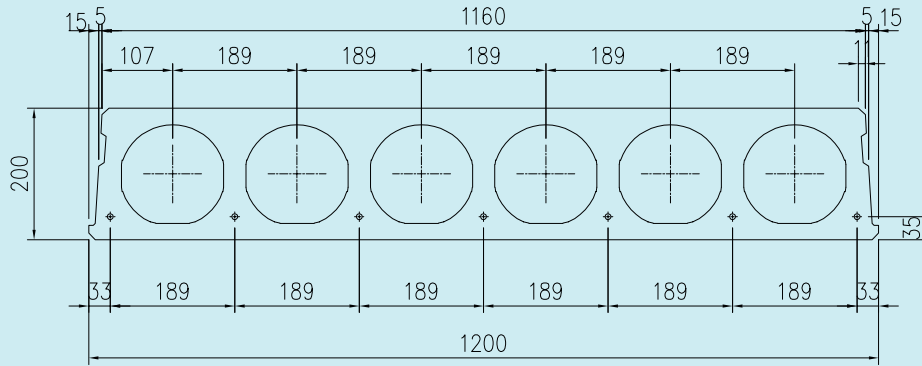

**Load Table 200 HCS**

STRAND PATTERN	BEARING CAPACITY PER SLAB UNIT (1.20 M WIDTH)	SPAN (m)	4	5	6	7	8	9		
4S - 12.5mm $M_{cr} = 67.5 \text{ kN-m}$	$M_{SLS} = 56.3 \text{ kN-m}$	$q_{SLS} \text{ (kN/m}^2\text{)}$	18.8	12.8	8.0	5.2	3.4	1.6		
	$M_{ULS} = 83.8 \text{ kN-m}$	$q_{ULS} \text{ (kN/m}^2\text{)}$	28.2	19.2	12.0	7.8	5.1	2.4		
	$V_{UD} = 76.0 \text{ kN}$	c (mm)	-3.5	-4.9	-6.0	-6.4	-5.5	-2.9		
5S - 12.5mm $M_{cr} = 76.9 \text{ kN-m}$	$M_{SLS} = 64.1 \text{ kN-m}$	$q_{SLS} \text{ (kN/m}^2\text{)}$	18.4	13.8	10.6	7.0	4.8	2.6		
	$M_{ULS} = 103.7 \text{ kN-m}$	$q_{ULS} \text{ (kN/m}^2\text{)}$	27.6	20.7	15.9	10.5	7.2	3.9		
	$V_{UD} = 77.0 \text{ kN}$	c (mm)	-4.6	-6.6	-8.5	-9.8	-10.0	-8.5		
6S - 12.5mm $M_{cr} = 89.9 \text{ kN-m}$	$M_{SLS} = 74.6 \text{ kN-m}$	$q_{SLS} \text{ (kN/m}^2\text{)}$	18.0	13.6	10.6	8.6	5.6	3.4		
	$M_{ULS} = 123.4 \text{ kN-m}$	$q_{ULS} \text{ (kN/m}^2\text{)}$	27.0	20.4	15.9	12.9	8.4	5.1		
	$V_{UD} = 78.2 \text{ kN}$	c (mm)	-5.6	-8.3	-11.0	-13.3	-14.5	-14.1		
7S - 12.5mm $M_{cr} = 93.4 \text{ kN-m}$	$M_{SLS} = 77.8 \text{ kN-m}$	$q_{SLS} \text{ (kN/m}^2\text{)}$		13.2	10.2	8.4	6.6	4.0		
	$M_{ULS} = 142.7 \text{ kN-m}$	$q_{ULS} \text{ (kN/m}^2\text{)}$		19.8	15.3	12.6	9.9	6.0		
	$V_{UD} = 78.5 \text{ kN}$	c (mm)		-10.1	-13.5	-16.8	-19.1	-19.9		
Slab Self weight = $2.25 \text{ kN/m}^2$	$M_{SLS}$ = Slab Moment Capacity (Service limit Stage)	$q_{SLS}$ = Maximum allowed imposed dead and live load, unfactored (excluding self weight of slab)								
Joint Filling = $0.11 \text{ kN/m}^2$	$M_{ULS}$ = Slab Moment Capacity (Ultimate limit Stage)	$q_{ULS}$ = Maximum allowed imposed dead and live load, factored (excluding self weight of slab)								
Total Self weight = $2.36 \text{ kN/m}^2$	$V_{UD}$ = Slab Shear Capacity (Ultimate limit Stage)	C = Theoretical camber at time of installation (+ indicate deflection)								

**Load Table 200 HCS + 60mm Screed**

STRAND PATTERN	BEARING CAPACITY PER SLAB UNIT (1.20 M WIDTH)	SPAN (m)	4	5	6	7	8	9	10	
4S - 12.5mm $M_{cr} = 112.5 \text{ kN-m}$	$M_{SLS} = 93.8 \text{ kN-m}$	$q_{SLS} \text{ (kN/m}^2\text{)}$	23.0	17.2	11.8	8.0	5.4	3.8		
	$M_{ULS} = 114.1 \text{ kN-m}$	$q_{ULS} \text{ (kN/m}^2\text{)}$	34.5	25.8	17.7	12.0	8.1	5.7		
	$V_{UD} = 95.1 \text{ kN}$	c (mm)	-3.3	-4.7	-5.9	-6.6	-6.3	-4.5		
5S - 12.5mm $M_{cr} = 117.4 \text{ kN-m}$	$M_{SLS} = 97.8 \text{ kN-m}$	$q_{SLS} \text{ (kN/m}^2\text{)}$	21.8	16.4	13.0	10.4	7.4	5.2		
	$M_{ULS} = 141.3 \text{ kN-m}$	$q_{ULS} \text{ (kN/m}^2\text{)}$	32.7	24.6	19.5	15.6	11.1	7.8		
	$V_{UD} = 94.4 \text{ kN}$	c (mm)	-4.3	-6.4	-8.3	-9.9	-10.5	-9.8		
6S - 12.5mm $M_{cr} = 124.8 \text{ kN-m}$	$M_{SLS} = 104.0 \text{ kN-m}$	$q_{SLS} \text{ (kN/m}^2\text{)}$	20.6	15.4	12.2	10.0	8.4	6.8	5.0	
	$M_{ULS} = 167.9 \text{ kN-m}$	$q_{ULS} \text{ (kN/m}^2\text{)}$	30.9	23.1	18.3	15.0	12.6	10.2	7.5	
	$V_{UD} = 93.3 \text{ kN}$	c (mm)	-5.4	-8.0	-10.7	-13.1	-14.8	-15.1	-123.7	
7S - 12.5mm $M_{cr} = 138.1 \text{ kN-m}$	$M_{SLS} = 115.1 \text{ kN-m}$	$q_{SLS} \text{ (kN/m}^2\text{)}$		14.4	11.4	9.2	7.8	6.6	5.6	
	$M_{ULS} = 194.0 \text{ kN-m}$	$q_{ULS} \text{ (kN/m}^2\text{)}$		21.6	17.1	13.8	11.7	9.9	8.4	
	$V_{UD} = 92.1 \text{ kN}$	c (mm)		-9.6	-13.1	-16.5	-19.1	-20.5	-20.4	
Slab Self weight = $2.25 \text{ kN/m}^2$	$M_{SLS}$ = Slab Moment Capacity (Service limit Stage)	$q_{SLS}$ = Maximum allowed imposed dead and live load, unfactored (excluding self weight of slab)								
Joint Filling = $0.11 \text{ kN/m}^2$	$M_{ULS}$ = Slab Moment Capacity (Ultimate limit Stage)	$q_{ULS}$ = Maximum allowed imposed dead and live load, factored (excluding self weight of slab)								
Total Self weight = $2.36 \text{ kN/m}^2$	$V_{UD}$ = Slab Shear Capacity (Ultimate limit Stage)	C = Theoretical camber at time of installation (+ indicate deflection)								

## HOLLOW CORE SLAB TYPE 265 HCS

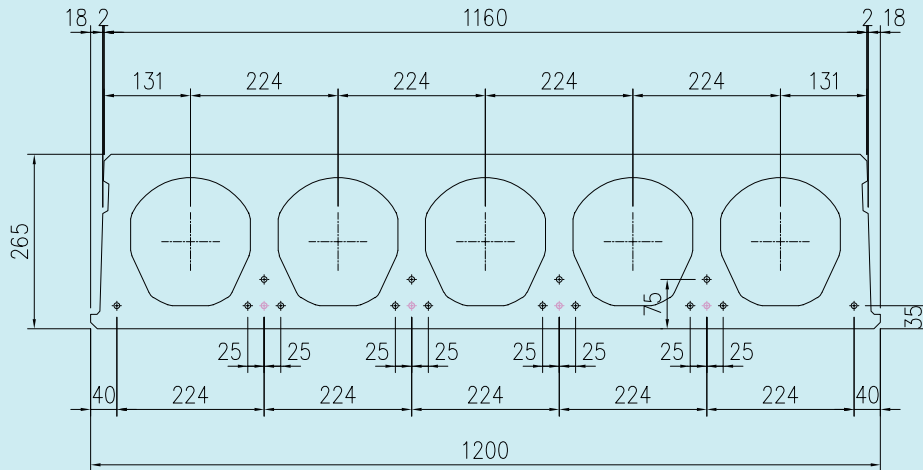

**Load Table 265 HCS**

STRAND PATTERN	BEARING CAPACITY PER SLAB UNIT (1.20 M WIDTH)	SPAN (m)	4	6	8	10	11	12	13
			$q_{SLS}$ (kN/m <sup>2</sup> )	29.2	11.4	4.8	2.0		
$M_{cr} = 106.4$ kN-m	$M_{SLS} = 88.3$ kN-m	$q_{SLS}$ (kN/m <sup>2</sup> )	29.2	11.4	4.8	2.0			
	$M_{ULS} = 117.8$ kN-m	$q_{ULS}$ (kN/m <sup>2</sup> )	43.8	17.1	7.2	3.0			
	$V_{UD} = 116.4$ kN	c (mm)	-2.1	-3.8	-3.9	2.8			
6S - 12.5mm	$M_{SLS} = 110.6$ kN-m	$q_{SLS}$ (kN/m <sup>2</sup> )	29.8	17.4	9.0	4.0	2.2		
	$M_{ULS} = 174.6$ kN-m	$q_{ULS}$ (kN/m <sup>2</sup> )	44.7	26.1	13.5	6.0	3.3		
	$V_{UD} = 122.3$ kN	c (mm)	-3.4	-6.7	-9.2	-8.3	-5.6		
8S - 12.5mm	$M_{SLS} = 130.5$ kN-m	$q_{SLS}$ (kN/m <sup>2</sup> )		17.6	11.8	5.8	3.6		
	$M_{ULS} = 229.9$ kN-m	$q_{ULS}$ (kN/m <sup>2</sup> )		26.4	17.7	8.7	5.4		
	$V_{UD} = 127.5$ kN	c (mm)		-9.7	-14.6	-16.7	-15.8		
10S - 12.5mm	$M_{SLS} = 149.9$ kN-m	$q_{SLS}$ (kN/m <sup>2</sup> )		17.6	12.0	7.6	5.2	3.4	2.0
	$M_{ULS} = 283.7$ kN-m	$q_{ULS}$ (kN/m <sup>2</sup> )		26.4	18.0	11.4	7.8	5.1	3.0
	$V_{UD} = 132.1$ kN	c (mm)		-12.8	-20.1	-25.2	-26.1	-25.2	-22.1

Slab Self weight = 2.25kN/m<sup>2</sup>     $M_{SLS}$  = Slab Moment Capacity (Service limit Stage)     $q_{SLS}$  = Maximum allowed imposed dead and live load,unfactored (excluding selfweight of slab)  
 Joint Filling = 0.11kN/m<sup>2</sup>     $M_{ULS}$  = Slab Moment Capacity (Ultimate limit Stage)     $q_{ULS}$  = Maximum allowed imposed dead and live load ,factored (excluding selfweight of slab)  
 Total Selfweight = 2.36kN/m<sup>2</sup>     $V_{UD}$  = Slab Shear Capacity (Ultimate limit Stage)    C = Theoretical camber at time of installation (+ indicate deflection)

**Load Table 265 HCS + 80mm Screed**

STRAND PATTERN	BEARING CAPACITY PER SLAB UNIT (1.20 M WIDTH)	SPAN (m)	4	6	8	10	11	12	13
			$q_{SLS}$ (kN/m <sup>2</sup> )		19.6	13.6	9.8	8.0	6.2
$M_{cr} = 234.1$ kN-m	$M_{SLS} = 195.1$ kN-m	$q_{SLS}$ (kN/m <sup>2</sup> )		19.6	13.6	9.8	8.0	6.2	4.4
	$M_{ULS} = 309.0$ kN-m	$q_{ULS}$ (kN/m <sup>2</sup> )		29.4	20.4	14.7	12.0	9.3	6.6
	$V_{UD} = 149.1$ kN	c (mm)		-9.3	-14.3	-17.0	-16.9	-15.1	-11.5
10S - 12.5mm	$M_{SLS} = 220.9$ kN-m	$q_{SLS}$ (kN/m <sup>2</sup> )		18.4	12.8	9.2	8.0	7.0	6.0
	$M_{ULS} = 380.8$ kN-m	$q_{ULS}$ (kN/m <sup>2</sup> )		27.6	19.2	13.8	12.0	10.5	9.0
	$V_{UD} = 150.3$ kN	c (mm)		-12.2	-19.5	-25.1	-26.6	-26.6	-24.8

Slab Self weight = 2.25kN/m<sup>2</sup>     $M_{SLS}$  = Slab Moment Capacity (Service limit Stage)     $q_{SLS}$  = Maximum allowed imposed dead and live load,unfactored (excluding selfweight of slab)  
 Joint Filling = 0.11kN/m<sup>2</sup>     $M_{ULS}$  = Slab Moment Capacity (Ultimate limit Stage)     $q_{ULS}$  = Maximum allowed imposed dead and live load ,factored (excluding selfweight of slab)  
 Total Selfweight = 2.36kN/m<sup>2</sup>     $V_{UD}$  = Slab Shear Capacity (Ultimate limit Stage)    C = Theoretical camber at time of installation (+ indicate deflection)

## HOLLOW CORE SLAB TYPE 320 HCS

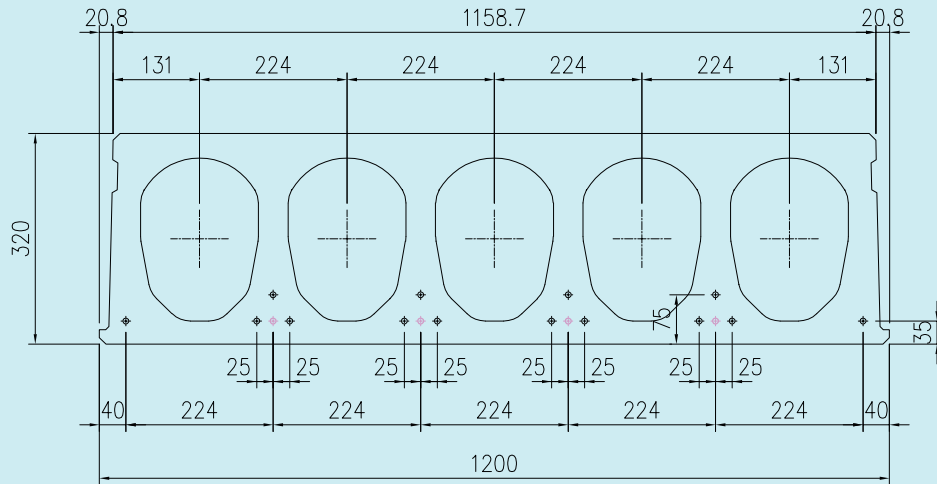

**Load Table 320 HCS**

STRAND PATTERN	BEARING CAPACITY PER SLAB UNIT (1.20 M WIDTH)	SPAN (m)	SPAN (m)								
			8	10	11	12	13	14	15	16	
6S - 12.5mm $M_{cr} = 176.9$ kN-m	$M_{SLS} = 147.4$ kN-m	$q_{SLS}$ (kN/m <sup>2</sup> )	11.4	5.8	4.0	2.2					
	$M_{ULS} = 217.9$ kN-m	$q_{ULS}$ (kN/m <sup>2</sup> )	17.1	8.7	6.0	3.3					
	$V_{UD} = 174.4$ kN	c (mm)	-7.3	-7.3	-5.8	-3.1					
8S - 12.5mm $M_{cr} = 206.9$ kN-m	$M_{SLS} = 172.4$ kN-m	$q_{SLS}$ (kN/m <sup>2</sup> )	16.4	9.0	6.0	3.8	2.4				
	$M_{ULS} = 287.7$ kN-m	$q_{ULS}$ (kN/m <sup>2</sup> )	24.6	13.5	9.0	5.7	3.6				
	$V_{UD} = 183.5$ kN	c (mm)	-11.3	-13.4	-13.3	-11.9	-9.0				
10S - 12.5mm $M_{cr} = 238.3$ kN-m	$M_{SLS} = 198.6$ kN-m	$q_{SLS}$ (kN/m <sup>2</sup> )		11.4	7.8	5.4	3.6	2.0			
	$M_{ULS} = 356.3$ kN-m	$q_{ULS}$ (kN/m <sup>2</sup> )		17.1	11.7	8.1	5.4	3.0			
	$V_{UD} = 191.9$ kN	c (mm)		-19.7	-20.9	-21.0	-19.6	-16.4			
12S - 12.5mm $M_{cr} = 264.0$ kN-m	$M_{SLS} = 220.0$ kN-m	$q_{SLS}$ (kN/m <sup>2</sup> )		13.0	9.2	6.4	4.4	2.8	1.6		
	$M_{ULS} = 412.4$ kN-m	$q_{ULS}$ (kN/m <sup>2</sup> )		19.5	13.8	9.6	6.6	4.2	2.4		
	$V_{UD} = 190.7$ kN	c (mm)		-24.2	-26.2	-27.2	-26.9	-24.8	-20.5		
Slab Self weight = 2.25kN/m <sup>2</sup>	$M_{SLS}$ = Slab Moment Capacity (Service limit Stage)	$q_{SLS}$ = Maximum allowed imposed dead and live load,unfactored (excluding selfweight of slab)									
Joint Filling = 0.11kN/m <sup>2</sup>	$M_{ULS}$ = Slab Moment Capacity (Ultimate limit Stage)	$q_{ULS}$ = Maximum allowed imposed dead and live load ,factored (excluding selfweight of slab)									
Total Selfweight = 2.36kN/m <sup>2</sup>	$V_{UD}$ = Slab Shear Capacity (Ultimate limit Stage)	C = Theoretical camber at time of installation (+ indicate deflection)									

**Load Table 320 HCS + 80mm Screed**

STRAND PATTERN	BEARING CAPACITY PER SLAB UNIT (1.20 M WIDTH)	SPAN (m)	SPAN (m)								
			8	10	11	12	13	14	15	16	
8S - 12.5mm $M_{cr} = 309.2$ kN-m	$M_{SLS} = 257.7$ kN-m	$q_{SLS}$ (kN/m <sup>2</sup> )		12.4	9.6	7.4	5.8	4.2	2.6		
	$M_{ULS} = 367.1$ kN-m	$q_{ULS}$ (kN/m <sup>2</sup> )		18.6	14.4	11.1	8.7	6.3	3.9		
	$V_{UD} = 206.2$ kN	c (mm)		-13.5	-13.8	-13.1	-11.0	-7.4	-3.5		
10S - 12.5mm $M_{cr} = 349.9$ kN-m	$M_{SLS} = 291.6$ kN-m	$q_{SLS}$ (kN/m <sup>2</sup> )		14.4	12.4	10.2	8.0	6.2	4.2	2.8	
	$M_{ULS} = 453.3$ kN-m	$q_{ULS}$ (kN/m <sup>2</sup> )		21.6	18.6	15.3	12.0	9.3	6.3	4.2	
	$V_{UD} = 211.8$ kN	c (mm)		-19.5	-21.0	-21.6	-21.0	-18.9	-14.9	-9.2	
12S - 12.5mm $M_{cr} = 381.9$ kN-m	$M_{SLS} = 318.3$ kN-m	$q_{SLS}$ (kN/m <sup>2</sup> )		12.6	11.0	9.6	8.4	7.6	5.6	4.0	
	$M_{ULS} = 526.8$ kN-m	$q_{ULS}$ (kN/m <sup>2</sup> )		18.9	16.5	14.4	12.6	11.4	8.4	6.0	
	$V_{UD} = 204.8$ kN	c (mm)		-23.8	-26.2	-27.7	-28.1	-27.0	-24.2	-19.1	
Slab Self weight = 2.25kN/m <sup>2</sup>	$M_{SLS}$ = Slab Moment Capacity (Service limit Stage)	$q_{SLS}$ = Maximum allowed imposed dead and live load,unfactored (excluding selfweight of slab)									
Joint Filling = 0.11kN/m <sup>2</sup>	$M_{ULS}$ = Slab Moment Capacity (Ultimate limit Stage)	$q_{ULS}$ = Maximum allowed imposed dead and live load ,factored (excluding selfweight of slab)									
Total Selfweight = 2.36kN/m <sup>2</sup>	$V_{UD}$ = Slab Shear Capacity (Ultimate limit Stage)	C = Theoretical camber at time of installation (+ indicate deflection)									

## HOLLOW CORE SLAB TYPE 400 HCS

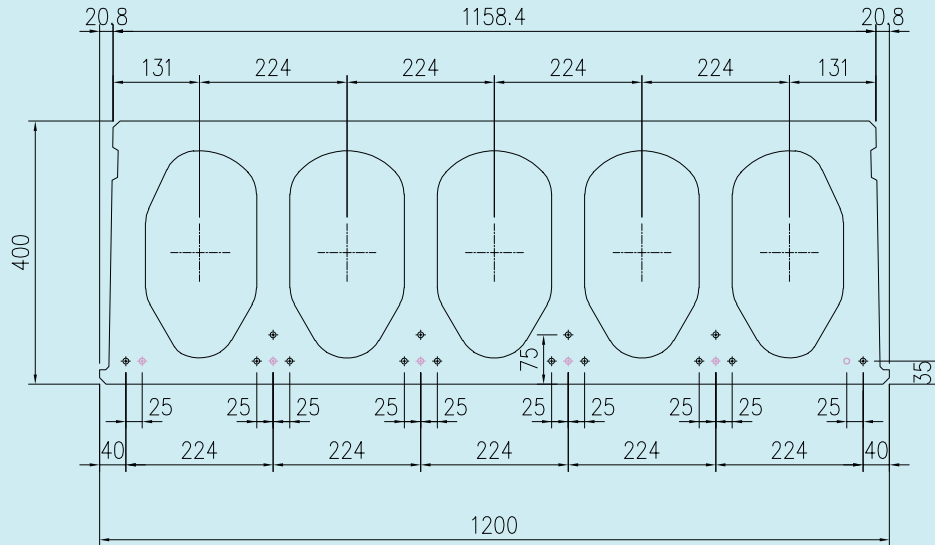

**Load Table 400 HCS**

STRAND PATTERN	BEARING CAPACITY PER SLAB UNIT (1.20 M WIDTH)	SPAN (m)	SPAN (m)							
			8	10	12	14	16	17	18	19
8S - 12.5mm $M_{cr} = 290.0 \text{ kN-m}$	$M_{SLS} = 241.7 \text{ kN-m}$	$q_{SLS} \text{ (kN/m}^2\text{)}$	21.2	11.6	6.4	2.2				
	$M_{ULS} = 371.6 \text{ kN-m}$	$q_{ULS} \text{ (kN/m}^2\text{)}$	31.8	17.4	9.6	3.3				
	$V_{UD} = 228.6 \text{ kN}$	$c \text{ (mm)}$	-7.6	-9.3	-8.7	-4.4				
10S - 12.5mm $M_{cr} = 333.9 \text{ kN-m}$	$M_{SLS} = 278.3 \text{ kN-m}$	$q_{SLS} \text{ (kN/m}^2\text{)}$		15.8	8.8	4.0				
	$M_{ULS} = 461.2 \text{ kN-m}$	$q_{ULS} \text{ (kN/m}^2\text{)}$		23.7	13.2	6.0				
	$V_{UD} = 234.6 \text{ kN}$	$c \text{ (mm)}$		-13.5	-14.7	-12.4				
12S - 12.5mm $M_{cr} = 372.0 \text{ kN-m}$	$M_{SLS} = 310.0 \text{ kN-m}$	$q_{SLS} \text{ (kN/m}^2\text{)}$		17.0	11.0	5.4	2.2			
	$M_{ULS} = 549.0 \text{ kN-m}$	$q_{ULS} \text{ (kN/m}^2\text{)}$		25.5	16.5	8.1	3.3			
	$V_{UD} = 244.9 \text{ kN}$	$c \text{ (mm)}$		-17.7	-20.8	-20.6	-15.2			
14S - 12.5mm $M_{cr} = 402.0 \text{ kN-m}$	$M_{SLS} = 335.0 \text{ kN-m}$	$q_{SLS} \text{ (kN/m}^2\text{)}$		16.2	12.4	6.6	3.2	2.0		
	$M_{ULS} = 625.1 \text{ kN-m}$	$q_{ULS} \text{ (kN/m}^2\text{)}$		24.3	18.6	9.9	4.8	3.0		
	$V_{UD} = 241.4 \text{ kN}$	$c \text{ (mm)}$		-21.0	-25.5	-26.9	-23.3	-19.0		
Slab Self weight = $2.25 \text{ kN/m}^2$	$M_{SLS}$ = Slab Moment Capacity (Service limit Stage)	$q_{SLS}$ = Maximum allowed imposed dead and live load,unfactored (excluding selfweight of slab)								
Joint Filling = $0.11 \text{ kN/m}^2$	$M_{ULS}$ = Slab Moment Capacity (Ultimate limit Stage)	$q_{ULS}$ = Maximum allowed imposed dead and live load ,factored (excluding selfweight of slab)								
Total Selfweight = $2.36 \text{ kN/m}^2$	$V_{UD}$ = Slab Shear Capacity (Ultimate limit Stage)	$C$ = Theoretical camber at time of installation (+ indicate deflection)								

**Load Table 400 HCS + 80mm Screed**

STRAND PATTERN	BEARING CAPACITY PER SLAB UNIT (1.20 M WIDTH)	SPAN (m)	SPAN (m)							
			8	10	12	14	16	17	18	19
10S - 12.5mm $M_{cr} = 454.4 \text{ kN-m}$	$M_{SLS} = 378.7 \text{ kN-m}$	$q_{SLS} \text{ (kN/m}^2\text{)}$		17.0	12.4	7.8	4.2	2.6		
	$M_{ULS} = 558.7 \text{ kN-m}$	$q_{ULS} \text{ (kN/m}^2\text{)}$		25.5	18.6	11.7	6.3	3.9		
	$V_{UD} = 256.7 \text{ kN}$	$c \text{ (mm)}$		-13.3	-15.0	-13.6	-7.6	-3.9		
12S - 12.5mm $M_{cr} = 503.5 \text{ kN-m}$	$M_{SLS} = 419.6 \text{ kN-m}$	$q_{SLS} \text{ (kN/m}^2\text{)}$		16.2	12.6	9.8	6.0	4.2	2.8	
	$M_{ULS} = 663.8 \text{ kN-m}$	$q_{ULS} \text{ (kN/m}^2\text{)}$		24.3	18.9	14.7	9.0	6.3	4.2	
	$V_{UD} = 258.9 \text{ kN}$	$c \text{ (mm)}$		-17.4	-20.8	-21.5	-17.7	-13.5	-8.2	
14S - 12.5mm $M_{cr} = 543.9 \text{ kN-m}$	$M_{SLS} = 453.3 \text{ kN-m}$	$q_{SLS} \text{ (kN/m}^2\text{)}$		13.8	10.4	8.2	6.4	5.6	3.8	2.6
	$M_{ULS} = 755.9 \text{ kN-m}$	$q_{ULS} \text{ (kN/m}^2\text{)}$		20.7	15.6	12.3	9.6	8.4	5.7	3.9
	$V_{UD} = 249.1 \text{ kN}$	$c \text{ (mm)}$		-20.5	-25.3	-27.6	-25.5	-22.3	-17.2	-10.9
Slab Self weight = $2.25 \text{ kN/m}^2$	$M_{SLS}$ = Slab Moment Capacity (Service limit Stage)	$q_{SLS}$ = Maximum allowed imposed dead and live load,unfactored (excluding selfweight of slab)								
Joint Filling = $0.11 \text{ kN/m}^2$	$M_{ULS}$ = Slab Moment Capacity (Ultimate limit Stage)	$q_{ULS}$ = Maximum allowed imposed dead and live load ,factored (excluding selfweight of slab)								
Total Selfweight = $2.36 \text{ kN/m}^2$	$V_{UD}$ = Slab Shear Capacity (Ultimate limit Stage)	$C$ = Theoretical camber at time of installation (+ indicate deflection)								



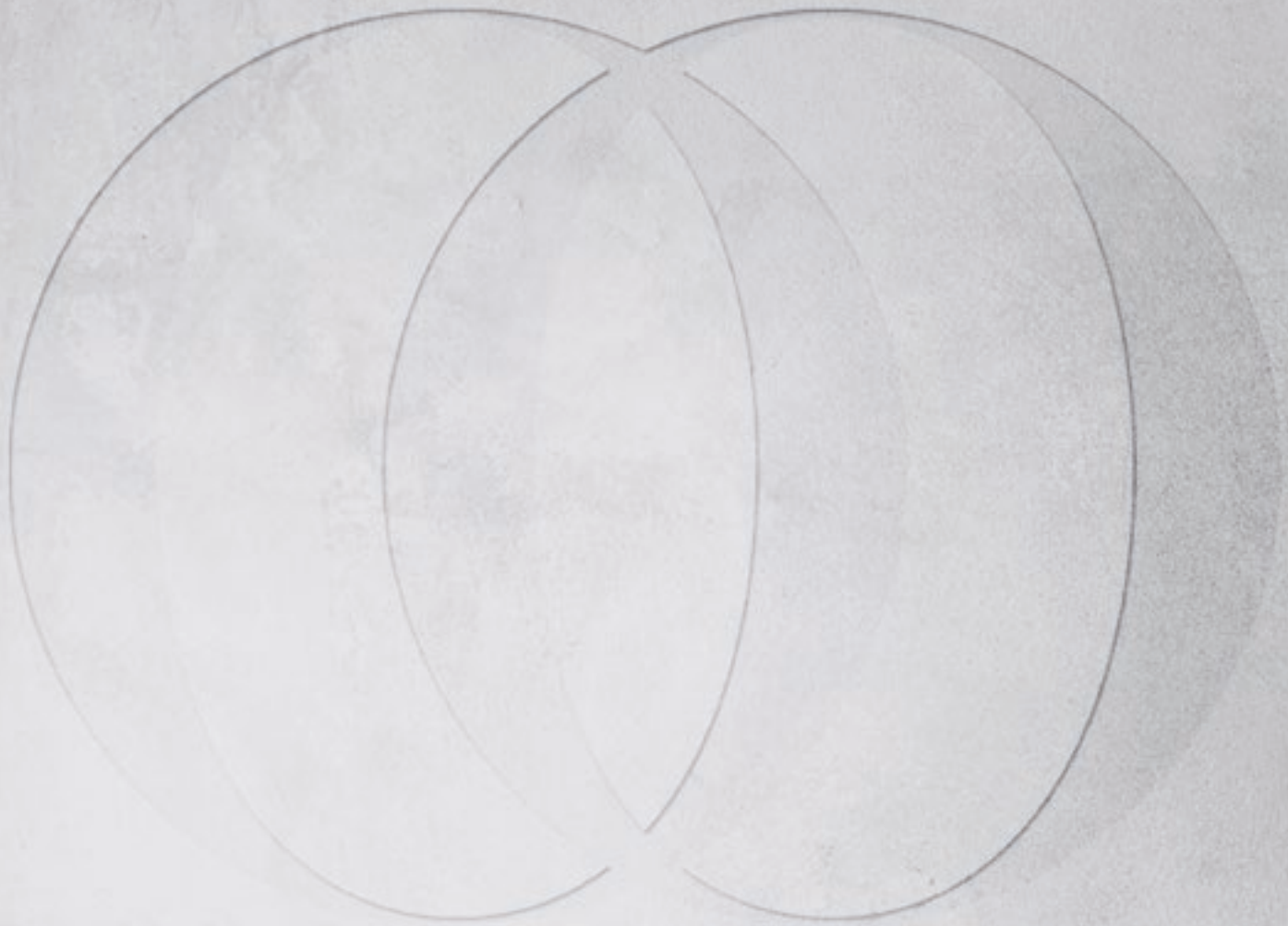

*We Lead. Others Follow.*

---

Oman Ophiolite LLC.

P.O.Box 457, PC 124 Rusayl,  
Sultanate of Oman.

**t** **f** (+968) 244 46412

[www.ophioman.com](http://www.ophioman.com) • [info@ophioman.com](mailto:info@ophioman.com)

---

 OmanOphioliteLLC

 Oman Ophiolite LLC